

**1 FOUNDATION & BEARER PLAN**  
Scale 1:100

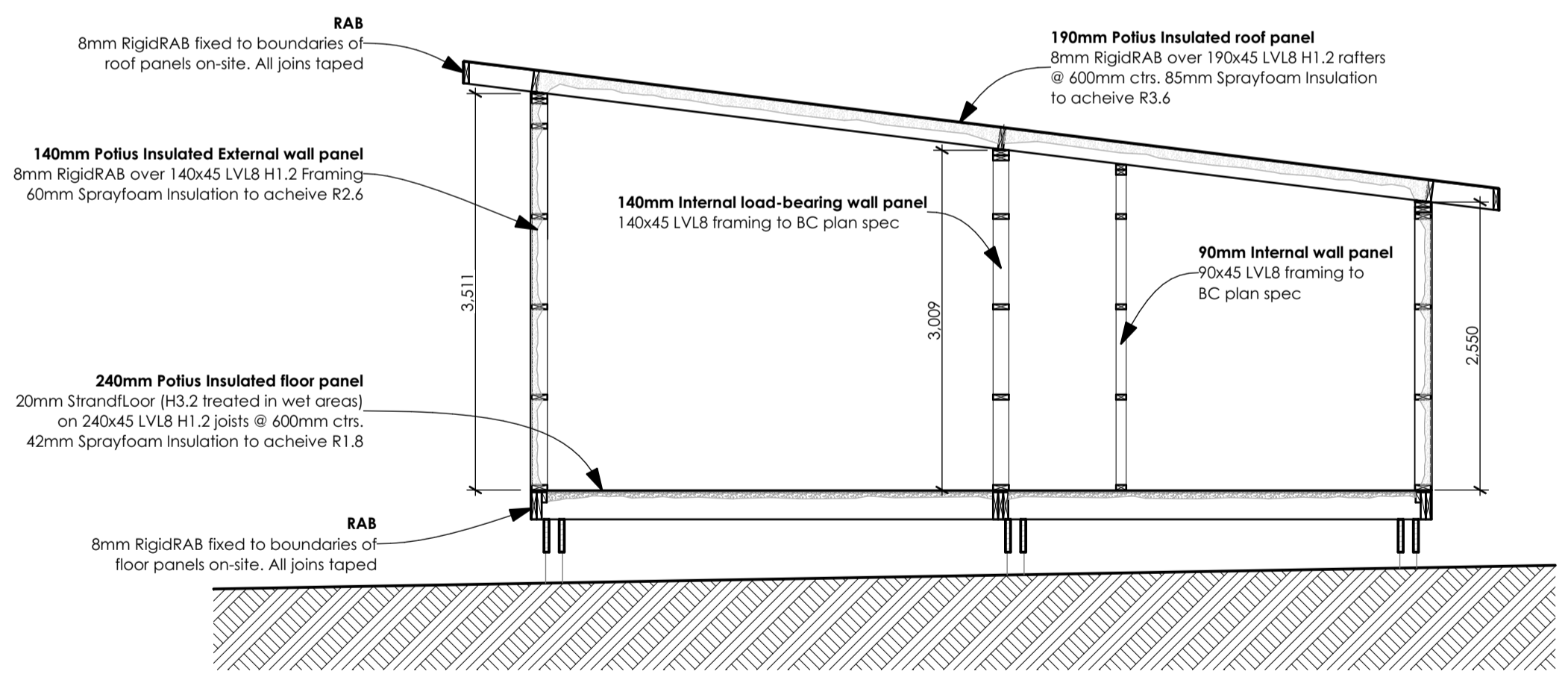

**2 SECTION ACROSS**  
Scale 1:50

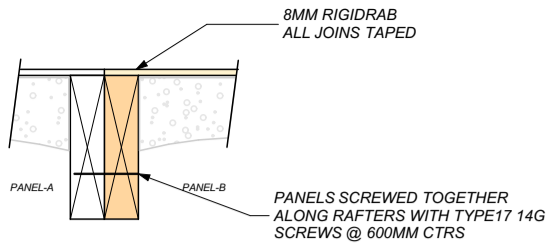

## 1 ROOF PANEL TO PANEL CONNECTION

Scale 1:10

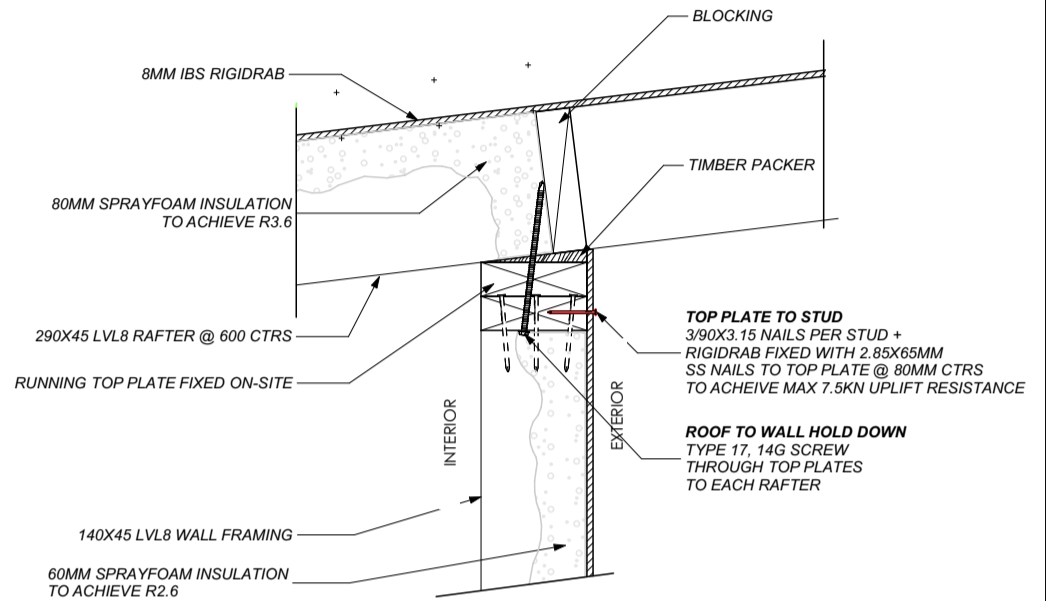
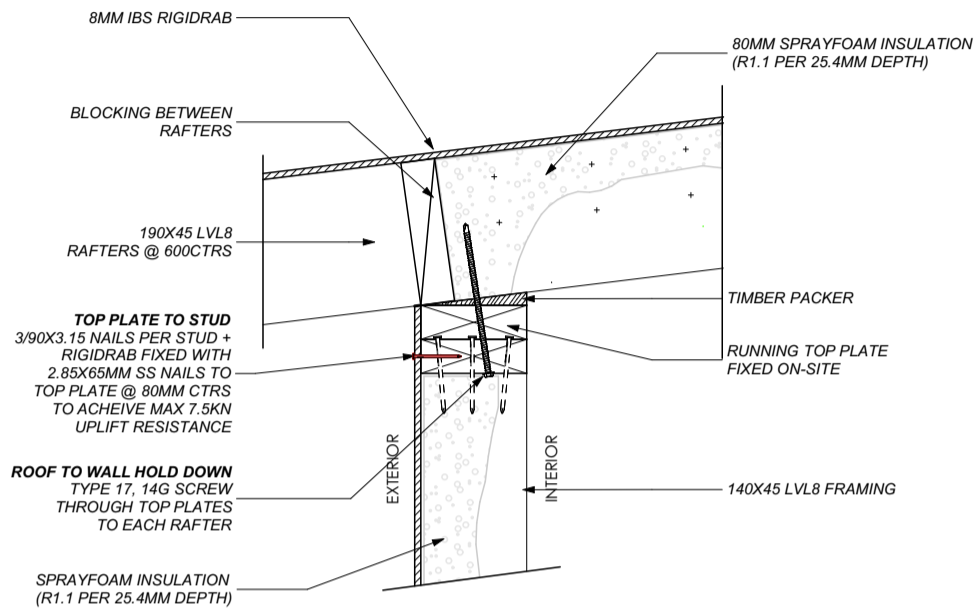

## 2 ROOF PANEL TO WALL CONNECTION

Scale 1:10

## 3 ROOF PANEL TO WALL CONNECTION

Scale 1:10

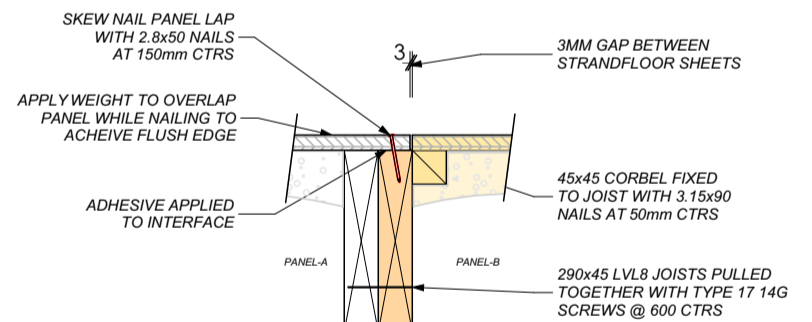
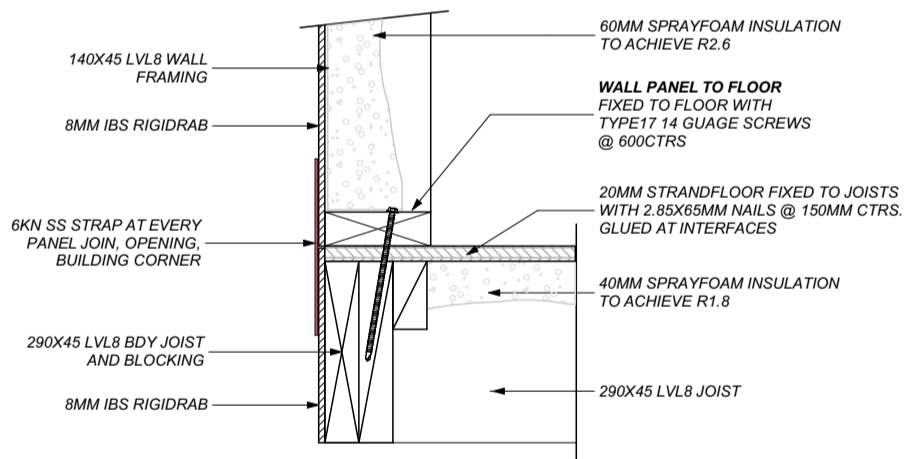

## 4 WALL PANEL TO FLOOR CONNECTION

Scale 1:10

## 5 FLOOR PANEL TO PANEL CONNECTION

Scale 1:10

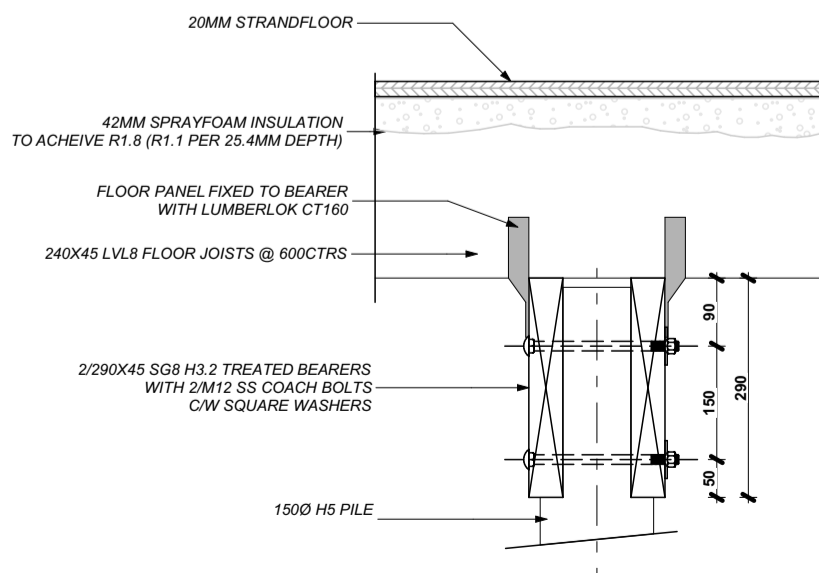

## 6 BEARER TO JOIST DETAIL

Scale 1:10

28/05/2020

JR

POTIUS  
DETAILS

Sheet number:

**S02**

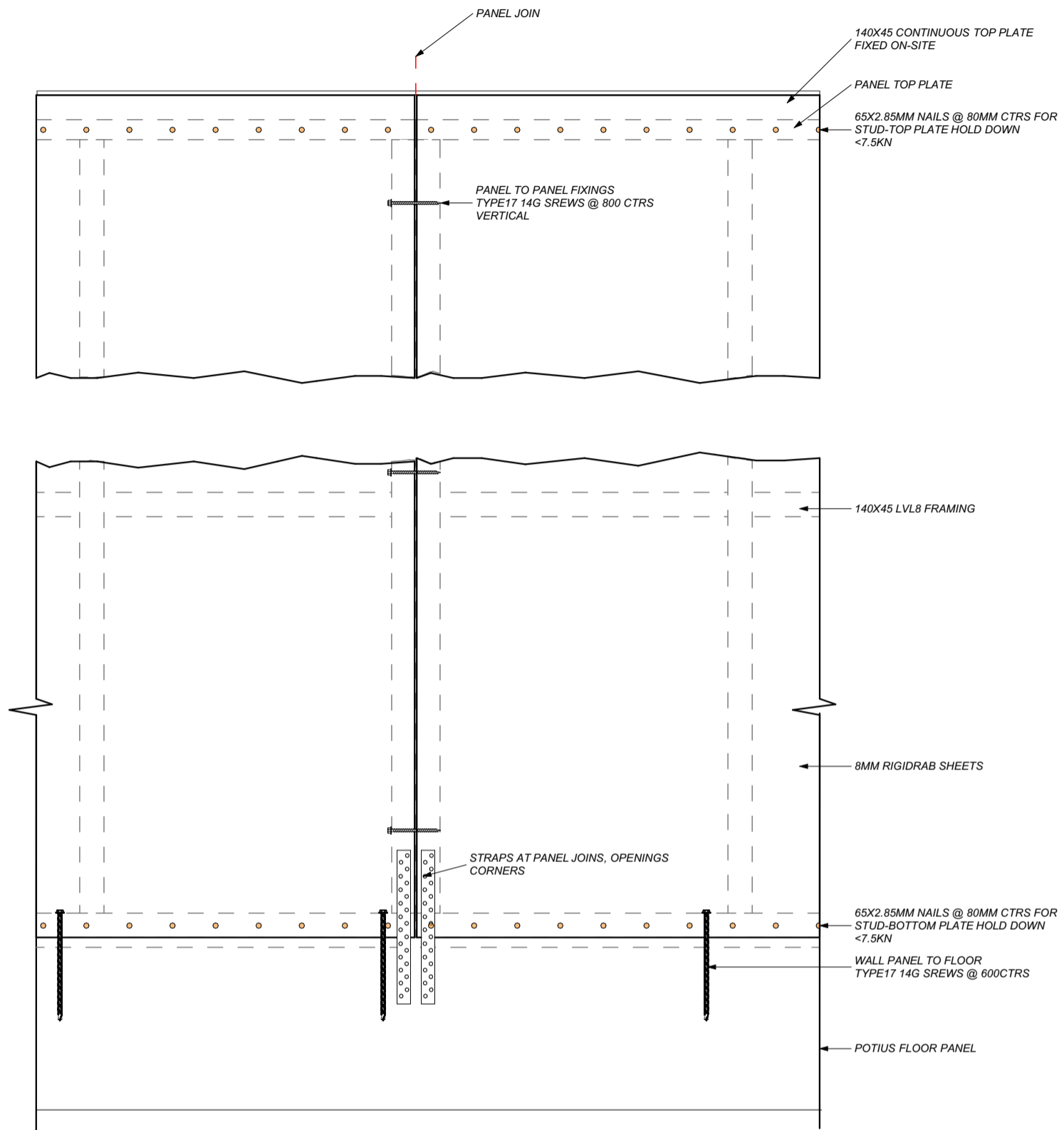

**1** WALL PANEL TO PANEL CONNECTION  
- Scale 1:10

28/05/2020

JR

POTIUS  
DETAILS

Sheet number:

**S03**